



INSTALLATION INSTRUCTIONS

FOR

**9430-4552 and 9430-4572
FREE DELIVERY PLENUM KITS**

**8330-752 CONTROL BOX KIT (12 VDC COOL ONLY)
9330C755 CONTROL BOX KIT (12 VDC HEAT READY)
8530-750 CONTROL BOX KIT (24 VAC COOL ONLY)
9530A751 CONTROL BOX KIT (12 VDC HEAT PUMP)**

**9430A751 ZONE CONTROL KIT (12 VDC COOL ONLY)
9430A755 ZONE CONTROL KIT (12 VDC HEAT READY)
9630A751 ZONE CONTROL KIT (12 VDC HEAT PUMP)**

**Airxcel, Inc.
RV Products Division
P.O. Box 4020
Wichita, KS 67204**

Coleman is a registered trademark of The Coleman Company, Inc. used under license. Mach is a registered trademark.

TABLE OF CONTENTS

1.	Warnings	2
2.	General Information and Requirements	2
3.	Package Contents	3
4.	System Match-Up	3
5.	Ceiling Plenum Installation Requirement	4
6.	Control Box Kits	5
7.	Control Box Kits (Zone)	5
8.	Wall Thermostats	5
9.	Routing Thermostat Wiring	5
10.	Routing Thermostat Wiring (Zone)	6
11.	Routing 115 VAC Wiring	6
12.	Securing the Upper Unit to the Roof	7
13.	Installing the Control Box	8
14.	Installing the Control Box (Zone)	9
15.	Installing the Heater Assembly	11
16.	Installing the Ceiling Assembly	12

1. WARNINGS

IMPORTANT NOTICE

These instructions are for the use of qualified individuals specially trained and experienced in installation of this type equipment and related system components.

Installation and service personnel are required by some states to be licensed. **PERSONS NOT QUALIFIED SHALL NOT SERVICE THIS EQUIPMENT.**

WARNING

Improper installation may damage equipment, can create a hazard and will void the warranty.

The use of components not tested in combination with these units will void the warranty, may make the equipment in violation of state codes, may create a hazard and may ruin the equipment.

WARNING – SHOCK HAZARD

To prevent the possibility of severe personal injury or equipment damage due to electrical shock, always be sure the electrical power to the appliance is disconnected during installation.

CAREFULLY FOLLOW ALL INSTRUCTIONS AND WARNINGS IN THIS BOOKLET TO AVOID DAMAGE TO THE EQUIPMENT, PERSONAL INJURY OR FIRE.

NOTE

The words “Shall” or “Must” indicate a requirement which is essential to satisfactory and safe product performance.

The words “Should” or May” indicate a recommendation which is not essential and not required, but which may be useful or helpful.

2. GENERAL INFORMATION AND REQUIREMENTS

This mount kit is designed to provide free delivery (no ducting) air distribution. It is applicable to **47000, 48000 and 49000 Series Roof Top Units Only**. The control box mounts inside the upper unit return air opening. The minimum recommended roof thickness with this system is 1”. The upper unit and ceiling assembly mount on a square roof opening 14” to 15” on a side. The roof must be capable of supporting 110 pounds of static load. Keep in mind that dynamic loads exist in recreation vehicles.

All manual controls have been removed from the ceiling plenum. They have been replaced with control relays.

The relays are mounted in the electrical box of the ceiling plenum. The relays contain 12 VDC coils (which may be energized by a wall mounted thermostat), with contacts that control the 115 VAC used to power the roof top unit.

A low voltage controller controls all air conditioning functions. The low voltage controller controls a 12 VDC electrical circuit, which is used to energize the relays in the ceiling plenum. The low voltage controller that Airxcel, Inc. provides for the system may be a combination (Heat/Cool).

These low voltage controllers are capable of operating both the roof top air conditioner and any furnace with a 12 VDC control circuit of 1 amp or less (continuous current).

All air conditioning equipment is subject to freeze up when evaporator air flow is sufficiently reduced. Ducting of any length creates potential for reduced evaporator air flow and system freeze up. To protect both the installer and Airxcel, Inc. from conditions that promote reduced air flow and system freeze up, Airxcel, Inc. has equipped the ceiling plenum compressor control circuit with a low temperature probe. The low temperature probe monitors

the temperature of the air conditioner evaporator coil. When the temperature of the evaporator coil drops below 28 degrees F, the switch will open, stopping compressor operation. Compressor operation will resume once the evaporator warms to 55 degrees F.

IMPORTANT

The low temperature sensor is part of the ceiling plenum electrical circuit. The probe must be inserted into the evaporator coil of the roof top unit by the installer when bolting the ceiling plenum to the roof top unit.

3. PACKAGE CONTENTS

The mounting kit package contains the following:

- 1) Steel mount frame
- 2) Ceiling shroud assembly
- 3) Supply duct assembly
- 4) Small parts package consisting of:
 - a) Mounting bolt (x4)
 - b) Mount screws (x11)

4. SYSTEM MATCH-UP

Ceiling Assembly Desired Function	Control Box Kit	Wall Thermostat
12 VDC Control Cooling Only	8330-752	7330G335 or 8330-336
12 VDC Control Cool/Heat Ready	9330C755	7330G335 or 8330-336
24 VAC Control Cooling Only	8530-750	7330B344 or 8330B324
12 VDC Control Heat Pump	9530A751	8530A345

Ceiling Assembly Desired Function	Control Box Kit	Wall Thermostat
12 VDC Zone Control Cooling Only	9430A751	9330A335
12 VDC Zone Control Cool/Heat Ready	9430A755	9330A335
12 VDC Zone Control Heat Pump	9630A751	9330A335

5. CEILING PLENUM INSTALLATION REQUIREMENT

1. The ceiling plenum must be installed under the roof opening.

The ceiling plenum bolts below the roof top unit. Compression of the framed ceiling cavity between the roof top unit and the ceiling plenum is what holds both components in place.
2. Ceiling cavity depth (the measurement from the ceiling to the roof – maximum 6”).
3. The 115 VAC service for the roof top unit must be routed into the ceiling plenum. To prevent wire pinching and to promote ease of installation, allowances must be made for routing the 115 VAC supply wiring into the front of the roof opening.
4. The wirebox has a 9 pin receptacle extending from the front. This mates with the roof unit 115 volt electrical conduit. When making this connection, verify that the plugs are properly aligned and have snapped together securely.

5. The wirebox for the heat/cool units will have a two pin receptacle which mates with the umbilical plug from the heater assembly.
6. **LOW VOLTAGE CONTROL WIRING (WALL THERMOSTAT)**
 - A. A low voltage terminal strip on the front of the box connects to the low voltage control wires. The wires attach by 1/4" quick connects.
 - B. The low voltage control wiring must be run from the wall thermostat mounting location to the wirebox low voltage terminals. To prevent wire pinching and to promote ease of installation, allowances must be made for routing the low voltage wiring into the front of the opening.

Standard Control Box

Cool Only Boxes	Plenum Terminal Designation	Thermostat Wire Connection	Function of Low Voltage Terminal Extending From Ceiling Plenum	Heat Ready Boxes
Yes	B	BLUE	Completes -12 VDC circuit for all relays	Yes
Yes	Y	YELLOW	Energizes coil on Compressor Relay	Yes
Yes	GH	GREEN	Energizes coil on High Fan Relay	Yes
Yes	GL	GRAY	Energizes coil on Low Fan Relay	Yes
Yes	FREEZE	WHITE	Evaporator Freeze Sensor Connections	Yes
Yes	FREEZE			
No	W	WHITE	Energizes coil on Heat Relay	Yes

Zone Control Box

Plenum Terminal Designation	Thermostat Wire Connection	Function of Low Voltage Terminal Extending From Ceiling Plenum
R+	Red	Provides +12 VDC to upper unit control box
Cool Shed (2 Terminals)	White Jumper Wire	Removing jumper wire will allow system to be connected to N.C. contacts of a load shed system
Heat Shed (2 Terminals)	White Jumper Wire	Removing jumper wire will allow system to be connected to N.C. contacts of a load shed system
Room (2 Terminals)	Any	The remote room temperature sensor attaches here*
Freeze (2 Terminals)	White	Freeze sensor attaches here
Gen	Any	Allows system to connect to an automatic start generator system
B-	Blue	Provides -12 VDC to upper unit control box
Sig 1	Purple	Communication line between upper unit control box and thermostat
Sig 2	Black	Communication line between upper unit control box and thermostat

* Zone 1 has option of using thermostat as room sensor

6. CONTROL BOX KITS

1. 8330-752 – 12 VDC Controlled, Cool Only

This kit consists of a control box assembly. The evaporator freeze sensor is shipped in an envelope for installation by quick connects to terminal strip “Freeze”.

2. 9330C755 – 12 VDC Controlled, Heat Ready

This kit consists of a control box assembly. The evaporator freeze sensor is shipped in an envelope for installation by quick connects to terminal strip “Freeze”. The heater assembly for the 47000 series is 47233*4551. The heater assembly for the 48000 and 49000 series is 9233*4551. Heat kits are purchased separately.

3. 8530-750 – 24 VAC Controlled, Cool Only

This kit is similar to the 8330-752 with the exception of a transformer that is attached to the box assembly.

4. 9530A751 – 12 VDC Controlled, Heat Pump

This kit is similar to the 9330C755 but is wired for the heat pump function. Backup electric heat is available. The heater assembly for the 47000 series is 47233*4551. The heater assembly for the 48000 and 49000 series is 9233*4551. Heat kits are purchased separately.

7. CONTROL BOX KITS (ZONE)

1. 9430A751 – 12 VDC Zone Controlled, Cool Only

This kit consists of a control box assembly. The evaporator freeze sensor is shipped in an envelope for installation by quick connects to terminal strip marked “FREEZE”.

2. 9430A755 – 12 VDC Controlled, Heat/Cool

This kit consists of a control box assembly. The evaporator freeze sensor is shipped in an envelope for installation by quick connects to terminal strip marked “FREEZE”. The heater assembly for the 47000 series is 47233*4551. The heater assembly for the 48000 and 49000 series is 9233*4551. Heat kits are purchased separately.

3. 9630A751 – 12 VDC Zone Controlled, Heat Pump

This kit consists of a control box assembly. The evaporator freeze sensor is shipped in an envelope for installation by quick connects to terminal strip marked “FREEZE”. Backup electric heat is available. The heater assembly for the 47000 series is 47233*4551. The heater assembly for the 48000 and 49000 series is 9233*4551. Heat kits are purchased separately.

8. WALL THERMOSTATS

1. Locate and install the thermostat per instructions found with the thermostat.
2. For 12 VDC thermostats, it is required that the thermostat 12 volt negative connection be routed

directly from the converter or battery. It is highly desirable provide 12 volt control power from the battery side of the converter. These precautions should prevent control problems.

9. ROUTING THERMOSTAT WIRING

1. Following the instructions packed with the thermostat, determine a location for thermostat mounting.
2. Following Airxcel, Inc. low voltage wiring specifications and all local and national electrical codes:
 - A. Route the thermostat 12 VDC supply wiring from the power source to the thermostat mounting location.

- Two wires are required:
One supply lead must be +12 VDC and red in color.
The second supply lead must be -12 VDC and blue in color.
- B. To protect the wall mount thermostat from over-current damage, a 2 amp fuse has been provided with the thermostat.
 - C. Route the thermostat control wiring from the thermostat mounting location into the front of the ceiling plenum opening.

Four (4) wires are required (5 wires for heat/cool boxes). These wires are as follows:

- (1) Blue wire for -12 VDC circuit
- (1) Yellow wire for compressor circuit
- (1) Green wire for high fan circuit
- (1) Gray wire for low fan circuit

- (1) White wire for heat circuit

3. Airxcel, Inc. low voltage wiring specifications:

- A. All low voltage wiring should be 18 gauge minimum.
- B. Low voltage wiring must be routed into the front side of the ceiling plenum opening.

10. ROUTING THERMOSTAT WIRING (ZONE)

1. Following the instructions packed with the thermostat, determine a location for thermostat mounting.

B. See Figure 5 for wiring requirements for multiple zones.

2. Following Airxcel, Inc. low voltage wiring specifications and all local and national electrical codes:

3. Airxcel, Inc. low voltage wiring specifications:

A. Route the thermostat control wiring from the thermostat mounting location into the front of the ceiling plenum opening.

A. All low voltage wiring should be no smaller than 18 gauge.

These wires are as follows:

B. Low voltage wiring must be routed into the front side of the ceiling plenum opening.

- (1) Red wire to +12 VDC circuit (R+)
- (1) Blue wire to -12 VDC circuit (B-)
- (1) Purple wire to communication signal (Sig 1)
- (1) Black wire to communication signal (Sig 2)
- (1) Any color for auto generator start (optional) (Gen)
- (2) Any color for room temperature sensor (zone 1 optional, required for other zones)
- (1) For each heating appliance (Up to 4)
- (2) Any color for cool load shed (optional)
- (2) Any color for heat load shed (optional)

C. Low voltage wiring should not be routed with high voltage wiring.

D. If low voltage and high voltage wires must cross, they should do so at right angles from one another.

11. ROUTING 115 VAC WIRING

Following Airxcel, Inc. high voltage wiring specifications and all local and national electrical codes, route the roof top unit 115 VAC supply wiring from its power source to the wirebox.

2. To prevent voltage drops greater than 10% during starting loads, adhere to the following guideline:

High Voltage Wiring Specifications based on Minimum Overcurrent Protection Device Amperage – (see upper unit nameplate)

1. U.L. requires copper conductors only with minimum #12 AWG when using the minimum recommended overcurrent protection device. Higher rated devices or longer wiring runs will require #10 AWG or greater copper conductors.

For lengths greater than 50', use #10 AWG or larger copper conductors. Match to the overcurrent protection device provided.

Circuit Protection – Refer to upper unit nameplate

High Voltage Wiring Specifications based on Overcurrent Protection Device rated higher than the minimum required (see upper unit nameplate)

Follow all local and NEC (National Electrical Code) for proper sizing of wire AWG based on Overcurrent Protection Device selected and the length of the wiring run to the air conditioner.

12. SECURING THE UPPER UNIT TO THE ROOF

The supplied mounting frame is used to secure the upper unit to the roof per the following steps (See Figure 1).

- A. Locate the upper unit mount gasket over the 14" to 15" square opening in the roof.
- B. Install the ceiling assembly mount frame using the four bolts found with the ceiling assembly.

- C. Proper tension has been achieved for each bolt when any portion of each gasket indicating tab has been pulled down even with the roof (See Figure 1). The upper unit has now been properly installed with optimum gasket compression.

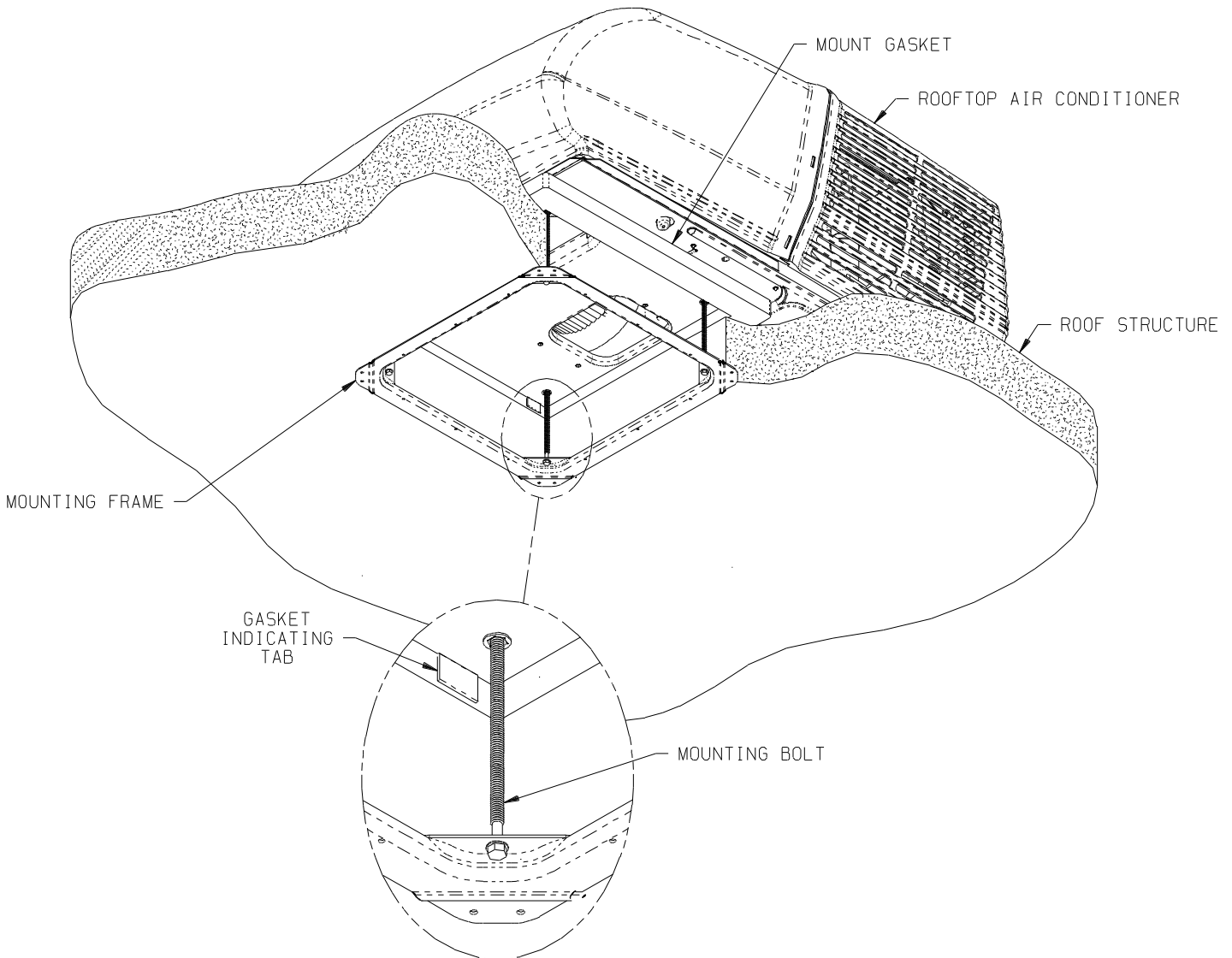
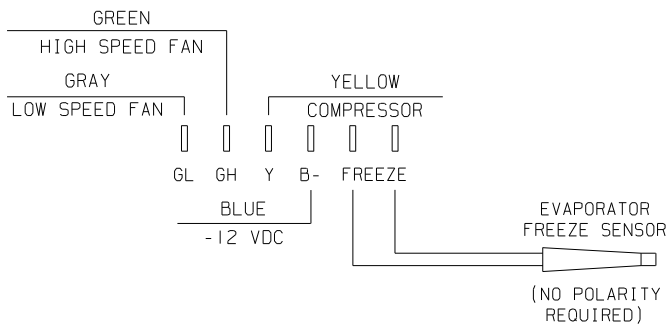

FIGURE 1
Representative of 47000, 48000 and 49000 Series Units

13. INSTALLING THE CONTROL BOX

1. Remove the control box assembly cover which is held by two sheet metal screws. Feed the field lead wires and ground through the strain relief found with the control box.
2. Attach black supply conductor to black "pigtail" lead, white to white and ground to green with wire nuts provided in control box kit.
3. Insure that no bare wires can come into contact with live electrical parts and that wires cannot be pinched between the control box sides and lid. Insert the strain relief into the control box entry hole to secure the field wiring. Reinstall the control box lid.
4. Attach the thermostat wires to the control box per illustrations below:

A. Control Box 8330-752



B. Control Box 9330C755, 9530A751

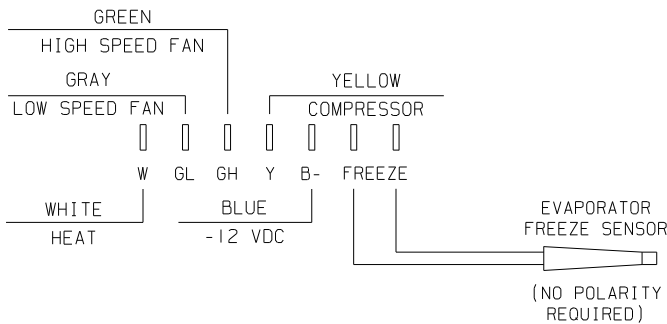

C. Control Box 8530-750

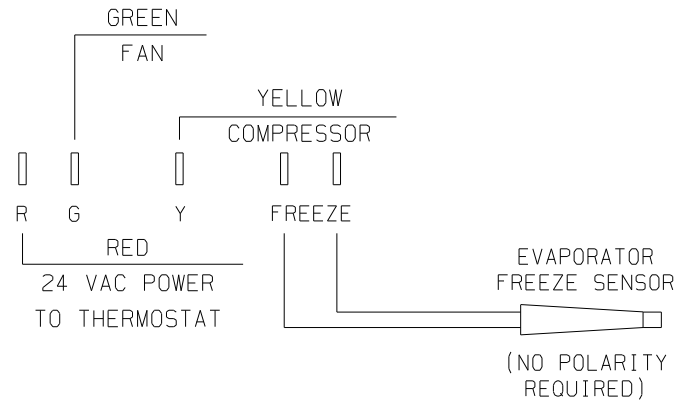

5. Connect the roof unit 115 volt electrical conduit to the wirebox 9 pin receptacle and verify that the plugs are properly aligned and have snapped together securely.
6. Locate the two machine screws inside the evaporator cover of the upper unit. Align the control box over the screws and use the wing nuts supplied with the control box to secure it to the upper unit enclosure. See Figure 2 for control box orientation in 48000 and 49000 series units. See Figure 9 for 47000 series units.
7. Insert the evaporator freeze sensor between evaporator fins near the bottom center of the evaporator and between the bottom two tubes (See Figure 2). Insert straight in until contacting the staggered tube directly in back of the insertion point. When contact has been made, elevate the exposed end of the sensor approximately 45 degrees, then continue insertion at a 45 degree angle until the sensor is completely embedded into the evaporator.

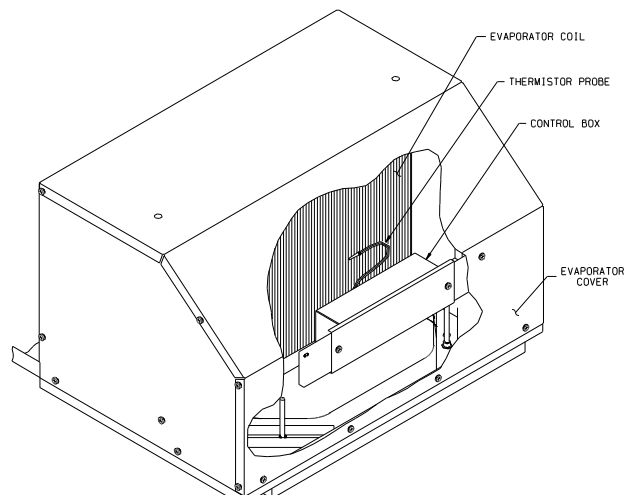

FIGURE 2

14. INSTALLING THE CONTROL BOX (ZONE)

1. Remove the control box assembly's cover which is held by two sheet metal screws.
2. Set the "zone" jumper to the proper zone position for the particular position the air conditioner or heat pump will be in the coach (**Refer to Figure 3 – Zone 1 is shown**). Zones should be numbered from the front of the back of the coach with Zone 1 in front.
3. Set the "HP"/"NON HP" jumper to "HP" if the unit is a heat pump or to "NON HP" if the unit is not a heat pump (**Refer to Figure 3 – Non HP is shown**).
4. Feed the field lead wires and ground through the strain relief found with the control box then through the 7/8" hole in the side of the box.
5. Wire nut the black field power conductor to the stripped black 12-gauge wire in the control box.
6. Wire nut the white field power conductor to the stripped white 12-gauge wire in the control box.
7. Wire nut the ground field power conductor to the stripped green ground wire in the control box.
8. Insure that no bare wires can come into contact with live electrical parts and that wire cannot be pinched between the control box sides and lid. Insert the strain relief into the control box entry hole to secure the field wiring. Reinstall the control box lid.

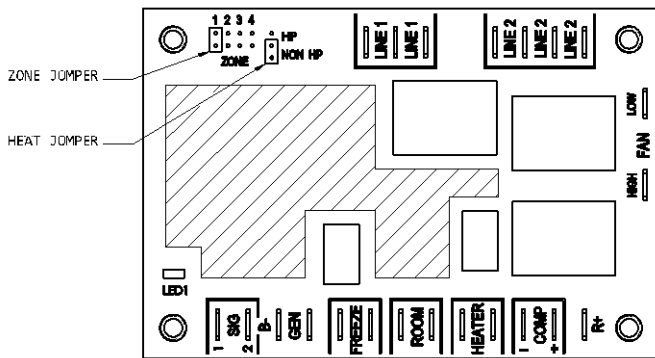

FIGURE 3

Attach the thermostat wires to Zone 1 control box per the illustration below (Refer to Figure 4):

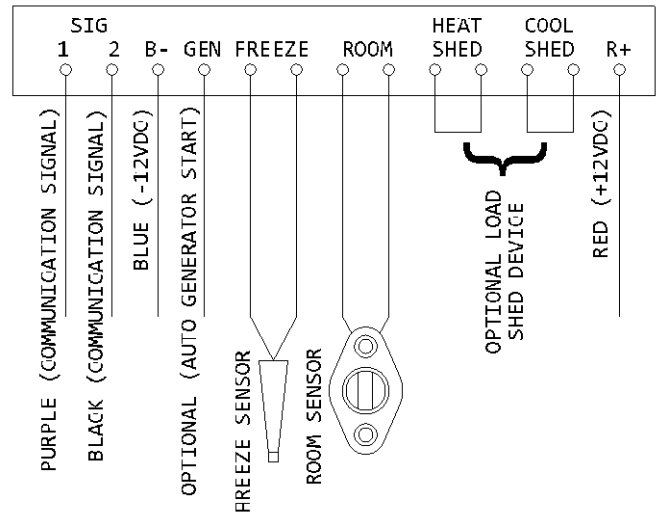

FIGURE 4

Zone 2 is wired in by jumpering from Sig 1, Sig 2, B- and R+ on Zone 1 box to Zone 2 box. Zone 3 is wired in by jumpering from Sig 1, Sig 2, B- and R+ on Zone 2 box to Zone 3 box. Zone 4 is wired in by jumpering from Sig 1, Sig 2, B- and R+ on Zone 3 box to Zone 4 box (See Figure 5).

Connect the roof unit 115 volt electrical conduit to the wirebox 9 pin receptacle and verify that the plugs are properly aligned and have snapped together securely.

Position the control box over the screws and use the wing nuts to fasten the control box to the upper unit enclosure. For 47000 series units, refer to Figure 9 on page 13. Note that the box is installed with the wiring exiting upwards. See Figure 2 for 48000 & 49000 series units.

Insert the evaporator freeze sensor between evaporator fins near the bottom center of the evaporator and between the bottom two tubes (See Figure 2). Insert straight in until contacting the staggered tube directly in back of the insertion point.

When contact has been made, elevate the exposed end of the sensor approximately 45 degrees, then continue insertion at a 45 degree angle until the sensor is completely embedded into the evaporator.

Complying with the warnings listed below, connect the 115 VAC supply wiring to its power source. Be sure all power remains off until beginning checkout procedure.

DANGER

TO PREVENT THE POSSIBILITY OF SHOCK INJURY FROM APPLIANCE OPERATION:

THE WHITE WIRE MUST BE CONNECTED TO NEUTRAL IN THE SERVICE BOX ENTRANCE AND THE MECHANICAL GROUND MUST BE CONNECTED TO A GROUNDING LUG IN THE SERVICE BOX OR THE MOTOR GENERATOR COMPARTMENT.

15. INSTALLING THE HEATER ASSEMBLY

NOTE

The optional Electric Heating Element is intended to take the chill out of the indoor air when the air is a few degrees too cool for comfort. The Electric Heating Element is an effective “chill chaser”. **It is not a substitute for a furnace.**

- A. If adding the electric heater to 48000 and 49000 series units, position the assembly in the upper unit return air opening as shown in Figure 6. The heater bracket must be installed over the metal basepan extrusion and positioned between the basepan and the plastic drain pan (See Figure 7). Tighten set screw to secure the assembly so as to prevent movement. 47000 series units will mount as shown in Figure 10 (see page 13) using wing nuts.

- B. Insert the two-pin connector of the heater umbilical into the receptacle on the control box. Insure that the connector snap-locks into position.

TIE ALL WIRING TO INSURE NO CONTACT WITH THE HEATER OR ANY SHARP EDGES. KEEP IN MIND THAT HIGH VELOCITY AIR WILL BE ENCOUNTERED IN THIS AREA.

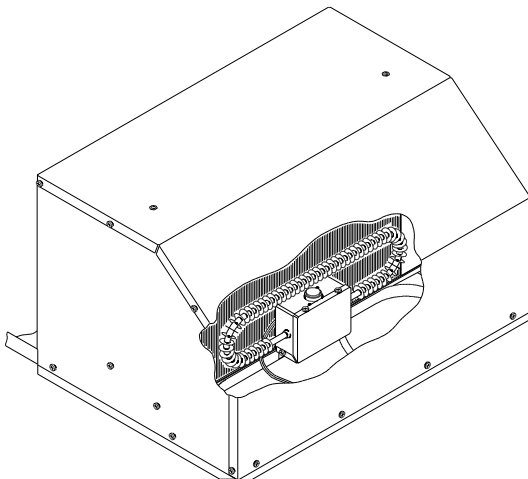

FIGURE 6

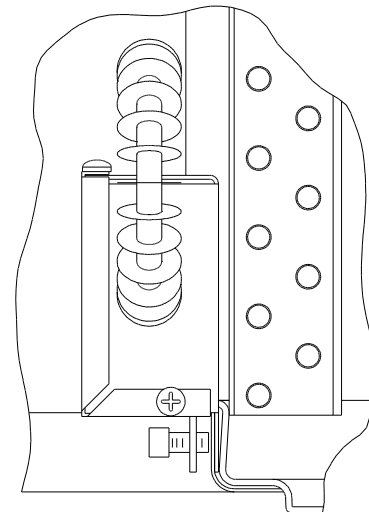

FIGURE 7

16. INSTALLING THE CEILING ASSEMBLY

- A. Separate ceiling assembly items and remove the two grilles and filters from the ceiling shroud.
- B. Fasten the duct collar to the basepan of the air conditioner with 3 provided screws (see Figure 8).
- C. Raise the ceiling assembly chute to the unit mounting frame and secure the chute with 4 provided screws (see Figure 8).
- D. Pull the fabric material through the ceiling chute discharge opening. Peel the release line from the adhesive strip around the opening. Press the fabric duct material firmly in place around opening. Cut off excess fabric on inside of ceiling chute with a box knife, taking care not to tear the fabric beyond the adhesive strip.
- E. Raise the ceiling assembly shroud, oriented as shown, and while insuring it meshes with the chute, secure to the mounting frame with 4 provided screws (see Figure 8).
- F. Re-install the filters and grilles into the ceiling assembly shroud.
- G. Turn ON the power supply to the roof top air conditioner.
- H. Follow the “System Operation and Checkout” guide in the thermostat installation instructions to insure proper operation

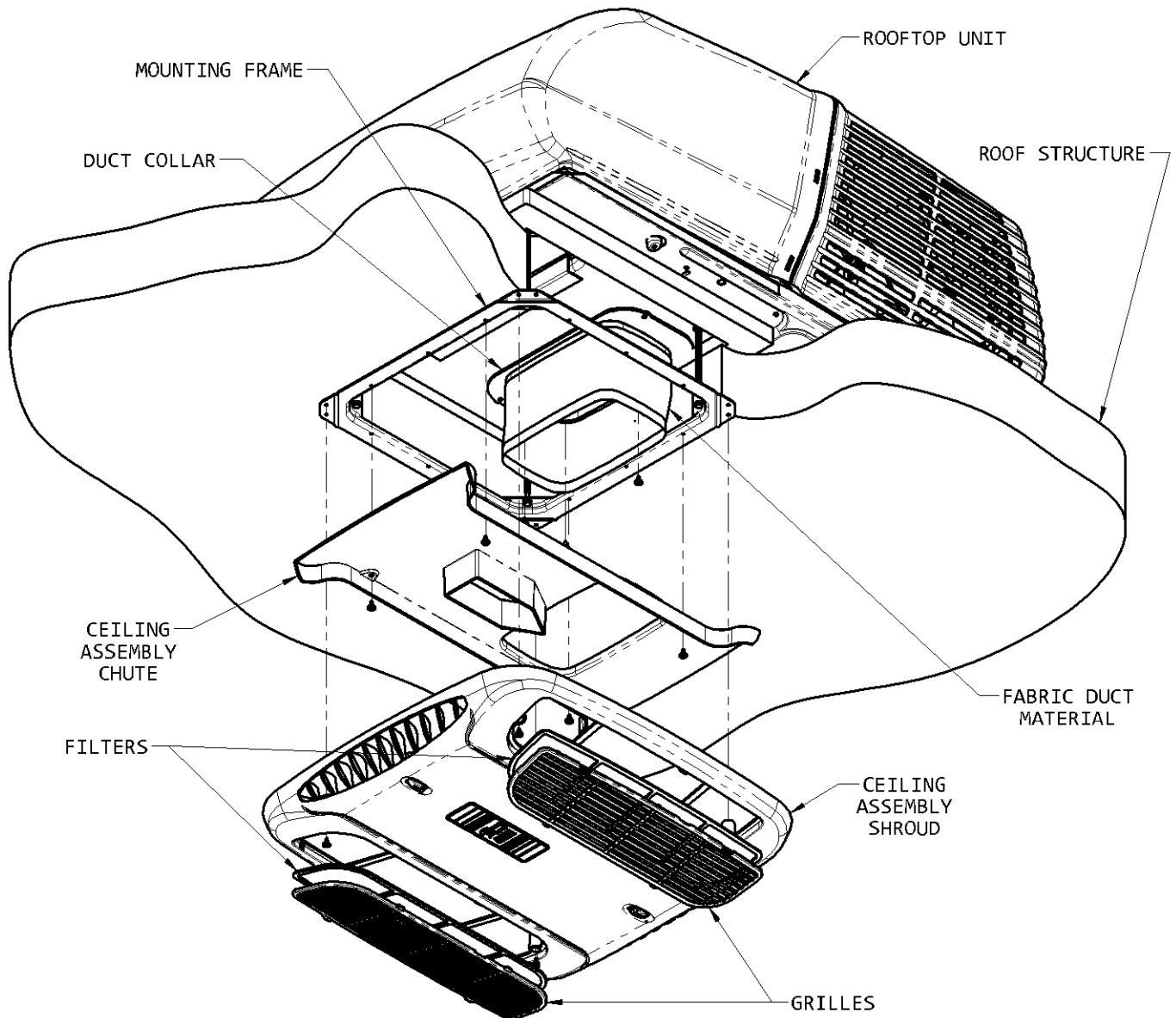

FIGURE 8

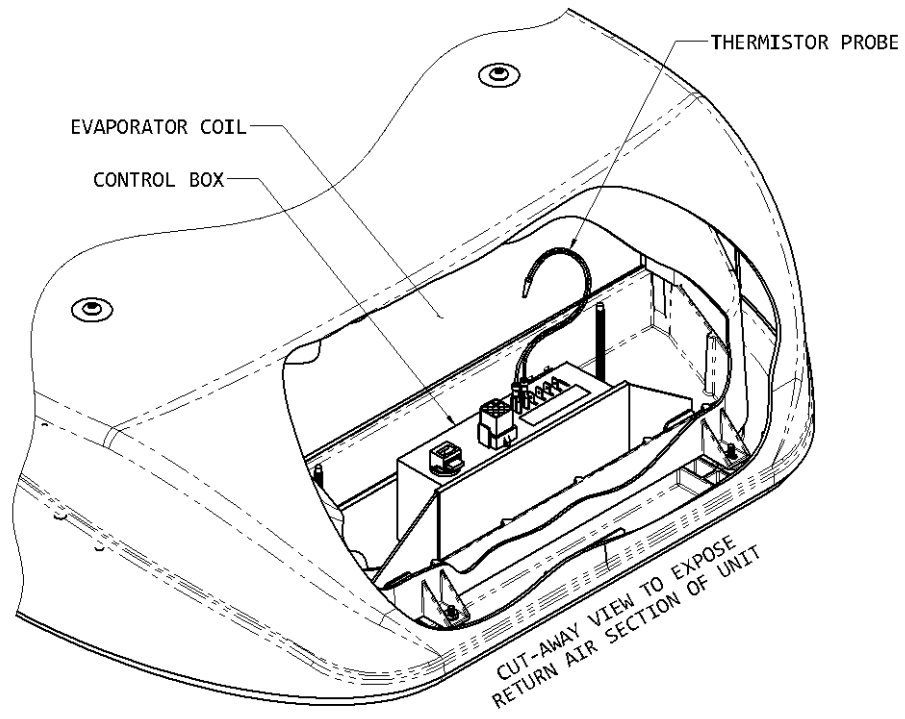

FIGURE 9

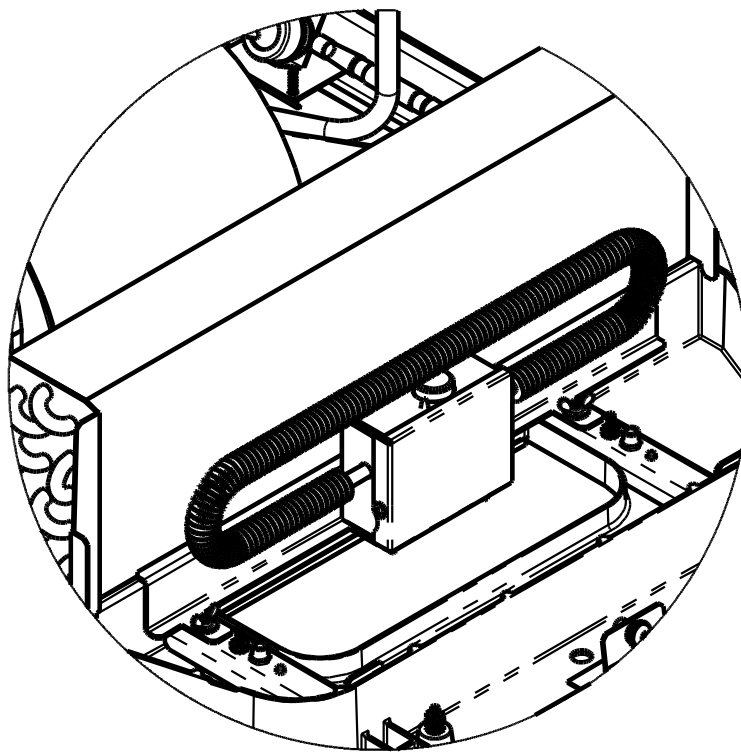

FIGURE 10